

EUROTECH 60CM HOTPLATE COOKTOP

ED-H60SS

INSTRUCTION MANUAL

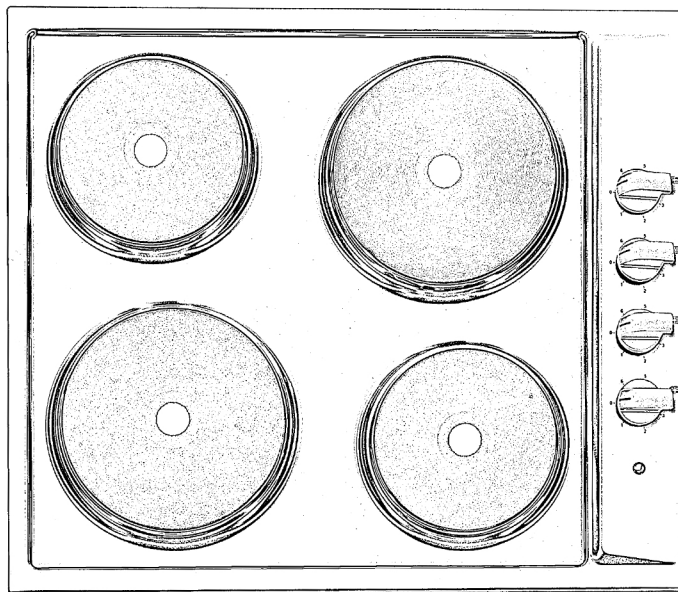

PLEASE READ THIS MANUAL CAREFULLY BEFORE
USING YOUR PRODUCT AND KEEP IT FOR FUTURE
REFERENCE.

Contents

Important safety information.....	3
Specifications.....	4
Using the hob.....	5
Cleaning and maintenance.....	7
Installation.....	8
My appliance isn't working correctly.....	11

NOTE: This User Instruction Manual contains important information, including safety & installation points, which will enable you to get the most out of your appliance. Please keep it in a safe place so that it is easily available for future reference; for you or any person not familiar with the operation of the appliance.

Important safety information



Your safety is of the utmost importance . Please make sure that you read this instruction booklet **before** attempting to install or use the appliance. If you are unsure of any of the information contained in this booklet, please contact the Technical service Department.

General Information

- This appliance is designed for domestic household use and for the cooking and frying of domestic foodstuffs..
- **IMPORTANT:** The adjacent furniture and all materials used in the installation **must** be able to withstand a minimum temperature of 85°C above the ambient temperature of the room it is located in, whilst in use.
- Certain types of vinyl or laminate kitchen furniture are particularly prone to heat damage or discolouration at temperatures below the guidelines given above.
- Any damage caused by the appliance being installed in contravention of this temperature limit, **will be the liability of the owner.**
- Your new appliance is guaranteed against electrical or mechanical defects. The foregoing does not affect your statutory rights.
- The use of this appliance for any other purpose or in any other environment without the express agreement. will invalidate any warranty or liability claim.
- You should not use this appliance to store items on or as a work surface.
- No modifications to the appliance are permitted.
- You should not store or place flammable or highly flammable liquids/materials on top of or near the appliance. Items made from aluminium, plastic or plastic film should also be kept away from the appliance, as they may fuse to the surface.
- **Repairs may only be carried out by authorised service agent.**

Child Safety

- Babies and young children are prevented from being near to the appliance and not allowed to touch the appliance at any time. During and after use, all surfaces will become hot.
- If it is necessary for younger family members to be in the kitchen, please ensure that they are kept under close supervision at all times.
- Older children should only be allowed to utilise the appliance when supervised.

General Safety

- √ The appliance should only be installed and connected by a suitable qualified person.
- √ Care should be taken to ensure that the units and work surfaces that you build the

appliance into, meet with the relevant standards.

- √If you notice any scratches, splits or cracks in the ceramic glass, you should immediately switch off the appliance and disconnect it from your mains supply. Otherwise there is the risk of electric shock occurring.

During use

- √Any film or stickers that are present on the hob surface when it is delivered should be removed before use.
- √Care should be used when utilizing the appliance, otherwise there is a risk of burns being caused.
- You should not allow the electrical connection cables to come into contact with the hob surface when it is hot or any hot cookware.
- If fat and oil overheats, then it can ignite extremely quickly. For this reason, when cooking with fat and oil the appliance should not be left unattended.
- √Make sure that all of the cooking zones are switched off after use.

Cleaning

- Cleaning of the hob should be carried out on a regular basis. The solid plates should also be maintained on a regular basis.
- **IMPORTANT:** Before attempting to clean the appliance or maintain the plates, it should be disconnected from the mains and cool.
- Great care should be taken whilst using this appliance and when following the cleaning procedure.
- You should not use a steam jet or any other high pressure cleaning equipment to clean the appliance.

Installation



This appliance must be correctly installed by a suitably qualified person, strictly in accordance with the manufacturer's instructions. Please see the specific section of this booklet that refers to installation.

To avoid damaging your appliance

- Cast iron and cast aluminium cookware with damaged bases may scratch the hob surface if they are dragged across it.
- Pans should be lifted on and off the hob surface and not dragged. 7
- Cooking zones should not be switched on without cookware placed on it. Also the cookware should not be empty.

Specifications

Product specifications:

ED H30 SS

- 1 x 2.00 kW thermostatic plates (diameter 180 mm)
- 1 x 1.50 kW thermostatic plates (diameter 145 mm)
- Side control operation

ED H60 SS

- o 2 x 2.00 kW thermostatic plates (diameter 180 mm)
- o 2 x 1.50 kW thermostatic plates (diameter 145 mm)
- o Side control operation

Electrical details

ED H30 SS

Rated Voltage: 220-230Vac 50/60 Hz
Supply Connection: 16 A (double pole switched fused outlet with 3mm contact gap)
Max Rated Inputs: 3.5 kW
Mains Supply Lead: 3 core x 1.5 mm² (not supplied)

ED H60 SS

Rated Voltage: 220-230Vac 50/60 Hz
Supply Connection: 30 A (double pole switched fused outlet with 3mm contact gap)
Max Rated Inputs: 7.00 kW
Mains Supply Lead: 3 core x 2.5 mm² (not supplied)

For future reference please record the following information which can be found on the rating plate and the date of purchase which can be found on your sales invoice. The rating plate of your hob is located on the underneath of the appliance. Therefore it is a good idea to record this information before you install your appliance.

Model Number
Serial Number
Date of Purchase

Hob surface layout

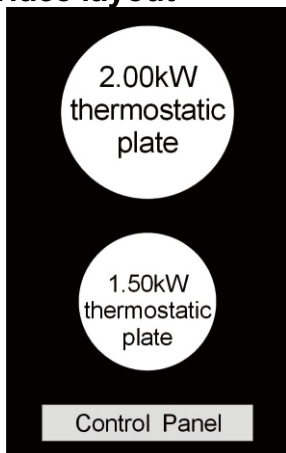

ED H30 SS

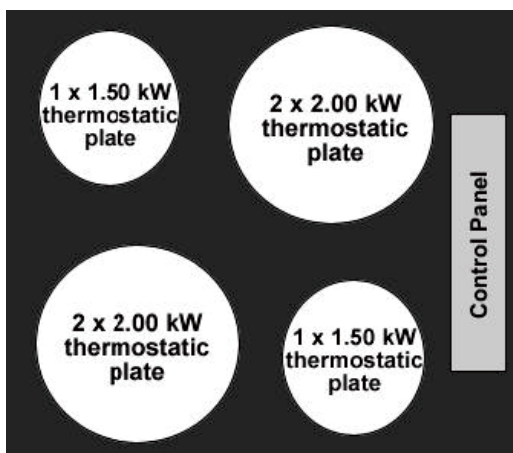

ED H60 SS

Using the hob

Before first use



IMPORTANT: You should clean the hob surface and solid plates (see “Cleaning and maintenance” section).

- You should switch on one cooking zone at a time, for 5 minutes at the maximum setting. This will help to eliminate any new smell that exists and evaporate any humidity that has formed on the heating elements during transit.
- When doing this burn off process, an appropriately sized saucepan containing cold water should be placed on the zone in question.
- Do not burn off more than one zone at once.

Control knobs

- All operations are performed by means of the 2 control knobs that can be found on the right hand side of the hob top.
- The control knobs can be turned either clockwise or anti-clockwise to select a heating level. The numbers around the outside of each control knob indicates the power level that you have set the zone to.
- A marking to the bottom right of each control knob, indicates which zone that it controls.

Turning on a zone and setting a power level

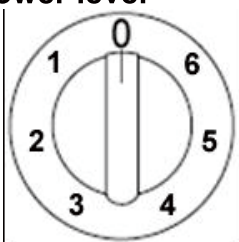

- Turn the control knob of the zone that you wish to cook on, clockwise or anticlockwise until it reaches the power level that you desire.
- Each cooking zone can be adjusted between 1 and 6, one being the coolest zone setting and six being the hottest zone setting.
- When you have finished cooking, make sure that you turn the control knob anti-clockwise, to the 0 position.

Hob guidelines

- The first few times the hob top is used, it may give off an acrid, burning smell. This smell will disappear completely with repeated use.
- The hob surface is fitted with cooking areas of different diameter and power.
- The positions where the heat will radiate from are clearly marked on the hob top. The saucepans must be positioned exactly on these zones for efficient heating to occur. Pans should have the same diameter as the cooking zone that they are being used on.
- You should not use saucepans with rough bottoms, as this can scratch the solid plates.
- Before use, make sure that the bottoms of the saucepans are clean and dry.
- When cold, the bottom of the pans should be slightly concave, as they expand when hot and lie flat on the surface of the hob. This will allow the heat to transfer more easily.

- The best thickness for the bottom of the pans is 2 – 3 mm of enameled steel and 4 – 6 mm for stainless steel with sandwich type bottoms.
- If these rules are not followed, then there will be a great loss of heat and energy. Heat not absorbed by the saucepan, will spread to the hob, frame and surrounding cabinets.
- Preferably cover pans with a lid to permit cooking at a lower heat.
- Always cook vegetables and potatoes, etc. in as little water to reduce cooking times.
- Food or liquid that has high sugar content may damage the hob top if it comes into contact with the hob surface. Any spillages should be wiped up immediately, however this may not prevent the hob surface from becoming damaged.
- **IMPORTANT:** The hob surface is tough; however it is not unbreakable and can be damaged. Especially if pointed or hard objects are allowed to fall on it with some force.
- **DO NOT USE THE HOB IF THE SURFACE BECOMES BROKEN OR CRACKED.**

Cleaning and maintenance



Cleaning and maintenance operations must only be carried out when the oven is cool.

The appliance should be disconnected from your mains supply before commencing any cleaning process.

Cleaning the hob top



Any residues that are left on the hob top surface from cleaning agents will damage it. You should remove any residues with water and a little washing up.



Abrasive cleaners or sharp objects will damage the hob surface; you should clean it using water and a little washing up liquid.



Although it is easier to clean some deposits whilst the hob surface is still warm. You should take care not to burn yourself if cleaning the hob surface when it is still warm.

After each use

- Wipe the appliance over with a damp cloth and a little washing up liquid.
- Dry the appliance by rubbing the surface with a clean cloth.
- If the hob top is heavily soiled then if the hob surface is made from stainless steel, then a suitable stainless steel cleaner should be used.
- **IMPORTANT: If a stainless steel cleaner is not used regularly, then it is possible for the surface of the hob to change colour over a period of time.**
- For other hob surfaces, a cleaner such as “Hob Brite” or “Bar Keepers Friend” may be appropriate.

Using a specialist hob cleaner

It is possible to purchase specialist ceramic hob cleaner/conditioner.

You should follow the instructions given by the manufacturer of the specialist ceramic hob cleaner. You should ensure that it is suitable for use on your appliance.

Maintaining the solid plates

- If something is spilt onto the plate itself, then it can be removed using a soft brush, plastic or nylon scourer and warm water.
- To keep the solid plates in good condition, you should put a little olive oil onto a kitchen towel and rub it onto the surface of the plate. The next time the plate is used, then it may

- produce a little smoke.
- Alternatively you can use a hotplate conditioner; these products can normally be found at larger supermarkets and hardware stores. The manufacturer's instructions should be followed when using these products.
- IMPORTANT: If the solid plates are not maintained regularly with olive oil or a hotplate conditioner, then they may rust.**

Installation

Positioning



The adjacent furniture must be able to withstand a minimum temperature rise of 85°C above the ambient temperature of the room it is located in, during periods of use.

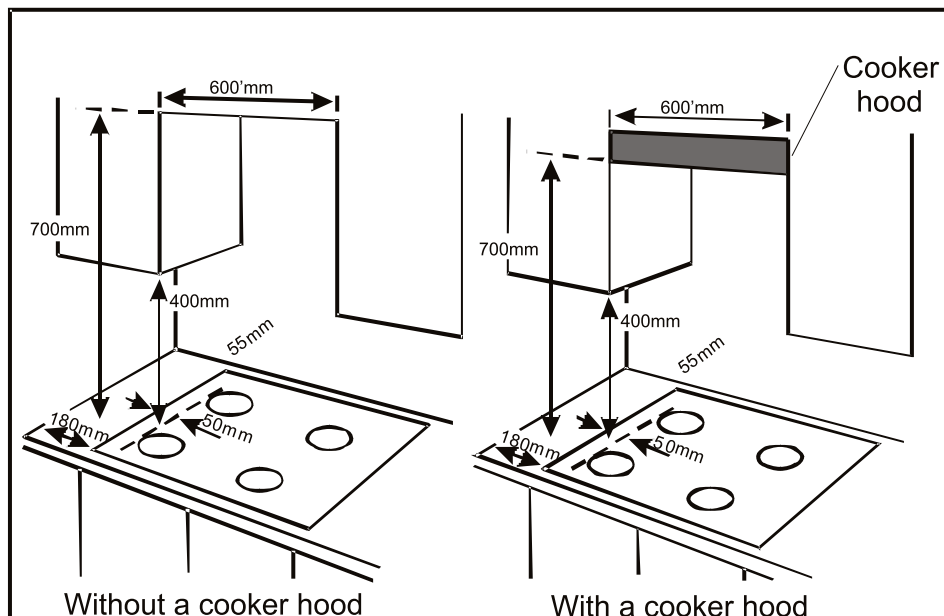

This appliance is classified as Class 3 and therefore is to be built into a kitchen unit (depending on size) or 600 mm worktop, providing the following minimum distances are allowed:

- 700 mm between the hob surface and the underside of any horizontal surface above it.
- 50 mm clearance around the appliance and between the hob surface and any combustible materials.

Unpacking the appliance

When unpacking the appliance please check that the following items are contained within the packaging:

- 1 Ceramic hob
- 1 Installation and instruction manual
- 4 Fixing screws
- 4 Clamps
- 1 Sealing strip

Installing the appliance

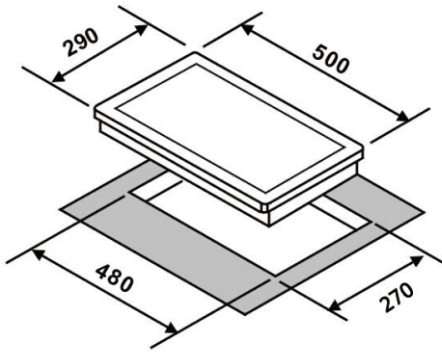

ED H30 SS

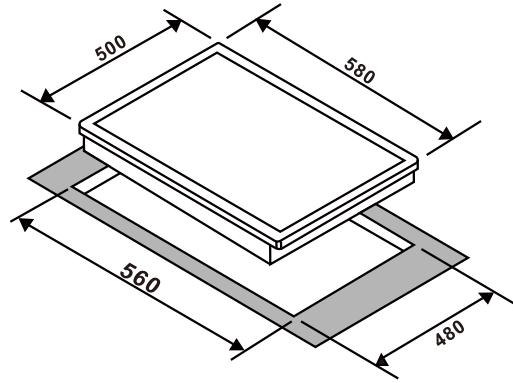

ED H60 SS

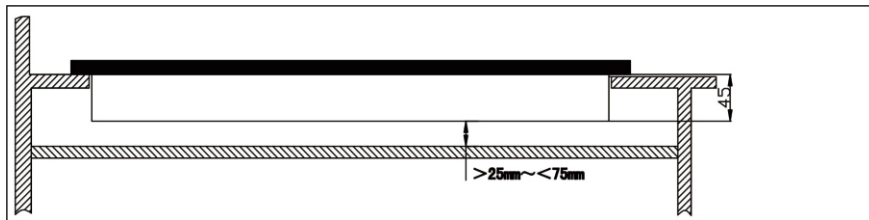

- Cut a hole in the worktop that corresponds with the drawings shown above.
- **IMPORTANT:** You must have at least 25-75 mm under the gap between the equipment and any surface below its

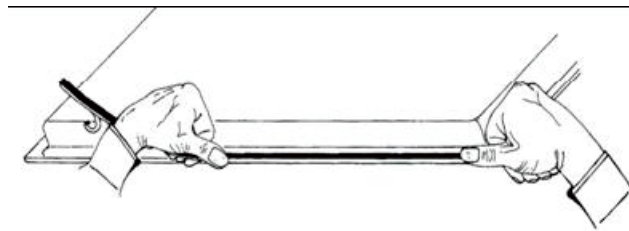

- Carefully turn the hob upside down and place it on a cushioned mat.
- Apply the sealing strip provided around the edge of the appliance.
- The protective covering must be removed from both sides.
- Do not leave a gap in the sealing agent or overlap the thickness.
- **IMPORTANT:** Do not use a silicon sealant to seal the appliance against the aperture. This will make it difficult to remove the hob from the aperture in future, particularly if it needs to be serviced.

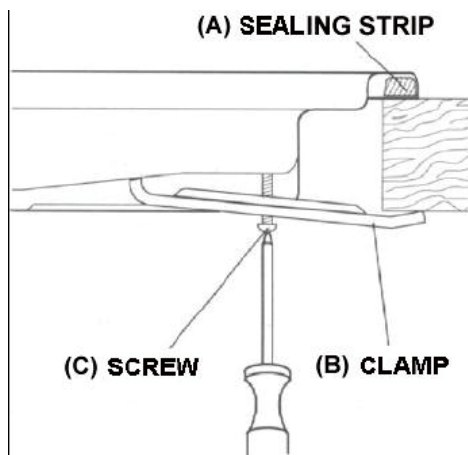

- (A) Sealing strip
- (B) Clamp
- (C) Screw

- Place the clamp **(B)** over the holes that match the size of the screws. There are one set of screw holes in each corner of the hob. Slightly tighten a screw **(C)** through the clamp **(B)** so that the clamp is attached to the hob, but so that you can still adjust the position of it.
- Carefully turn the hob back over and then gently lower it into the aperture hole that you have cut out.
- On the underneath of the hob, adjust the clamps into a position that is suitable for your worktop. Then fully tighten the screws **(C)** to secure the hob into position.

Electrical connection



This appliance must be installed by a qualified person .

Before connecting the appliance, make sure that the supply voltage marked on the rating plate corresponds with your mains supply voltage.

WARNING: THIS APPLIANCE MUST BE EARTHED.

- This appliance must be wired into a 16 A double pole switched fused spur outlet, having 3 mm contact separation and placed in an easily accessible position adjacent to the appliance. It should not be located above the appliance and no more than 1.25m away from it.
- The spur outlet must still be accessible even when your oven is located in its operating position.
- Cable type: H05 RRF 3 core x 1.5 mm²

Connecting the mains supply cable

- The mains terminal block is located on the underside of the hob and the terminals are accessible by removing the terminal block cover by removing the cover screw.
- The cable connections must be in accordance with the diagram located on the bottom of the hob.

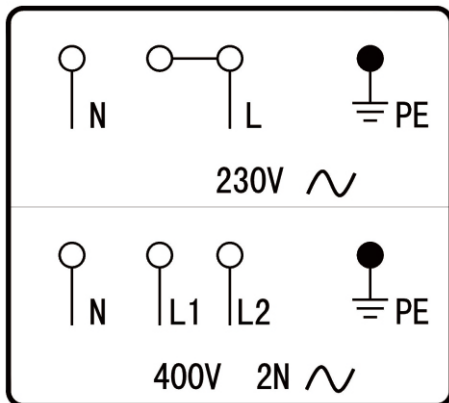

ED H30 SS

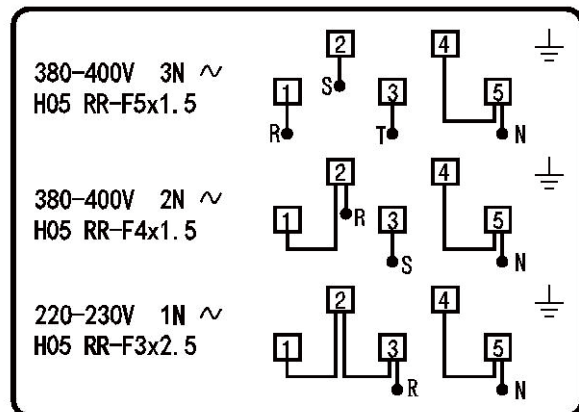

ED H60 SS

- The brass links must be positioned as marked in the appropriate diagram and once established ALL terminal screws must be tightened down firmly.
- **If when the hob is first switched on, only two of the zones work, you should recheck that the terminal screws are all fully tightened between the links.**

- **IMPORTANT:** The appliance must NOT be connected to the mains supply by means of a 13A plug and socket.
- The cable can be looped if necessary, but make sure that is not kinked or trapped when the hob is in position. Care must be taken to avoid the cable being in contact with hot parts of the appliance.

Replacing the mains supply cable

If the mains supply cable is damaged, then it must be replaced by an appropriate replacement which can be obtained from the seller . The mains supply cable should be replaced in accordance with the following instructions:

- **Switch the appliance off at the control switch.**
- Open the terminal block on the underside of the hob.
- Unscrew the terminal screws fixing the cable.
- Replace the cable with one of the same length and in accordance with the specification given above.
- The “green-yellow” earth wire must be connected to the terminal marked . It must be about 10 mm longer than the live and neutral wires.
- The “blue” neutral wire must be connected to the terminal marked with letter (N) - the live wire must be connected to the terminal marked with letter (L).

My appliance isn't working correctly

- **The cooking zones are not functioning or will not switch on.**
 - ★ Check that the mains electrical supply to the appliance is correct and working. Check the mains fuse.
- **A humming sound is heard when a cooking zone is selected.**
 - ★ This is normal; the sound will disappear when the zone heats up.
- **The cooking zones have become discoloured**
 - ★ This maybe caused by burnt on remnants of food. This will not affect the working of the appliance. However you should make sure that the cleaning instructions are being followed regularly.
- **Only two of the zones on my hob are working**
 - ★ You should recheck that the terminal screws are all fully tightened between the links.



IMPORTANT: If your appliance appears not to be operating correctly, then you should disconnect it from your mains supply and then contact the Service Department . DO NOT ATTEMPT TO REPAIR THE APPLIANCE YOURSELF.

Please note that if an engineer is asked to attend whilst the product is under guarantee and finds that the problem is not the result of an appliance fault, then you may be liable for the cost of the call out charge.

The appliance must be accessible for the engineer to perform any necessary repair. If your appliance is installed in such a way that an engineer is concerned that damage will be caused to the appliance or your kitchen, then he will not complete a repair.

This includes situations where appliances have been tiled in, sealed in with sealant, have wooden obstructions placed in front of the appliance, like plinths.